

# MV401-SERIES



## Diaphragm Valve

### Nominal width

- DN 15 to 200
- ANSI 1/2" to 8"

### Nominal pressure

- PN 10/16
- ANSI class 150

## Operating and maintenance instructions

**Armaturen AG**

**von Rohr**

**Pneumatic and electric control valves and appliance**

Fichtenhagstrasse 4, CH-4132 Muttenz 2, Phone +41 (0)61 467 91 20, Fax +41 (0)61 467 91 21  
e-mail: [info@von-rohr.ch](mailto:info@von-rohr.ch), [www.von-rohr.ch](http://www.von-rohr.ch)

1. Warning symbols	3
2. Safety advices	3
3. Qualified personnel	3
4. Storage	4
<b>I. Functional description</b>	<b>4</b>
<b>II. Installation</b>	<b>4</b>
1. Mounting location	4
2. Mounting	4
3. Type plate	5
<b>III. Initiation</b>	<b>5</b>
<b>IV. Maintenance</b>	<b>5</b>
<b>V. Dismounting / mounting the valve</b>	<b>6</b>
1. Procedure	6
2. Actuator	6
3. Cover flange (bonnet)	6
4. Closing piston / stem / diaphragm	6
5. Sealing elements / guidings	7
6. Replacing the diaphragm	7
<b>VI. Sectional drawing / bill of materials</b>	<b>8</b>
<b>VII. Torque table</b>	<b>9</b>
1. Control cover flange (bonnet fixing)	9
2. Flange screw fixing (conduit system)	9
<b>VIII. Spare parts offer / orders</b>	<b>10</b>

## 1. Warning symbols

Safety advices and warnings are made for preventing danger against life and health of users and maintenance personnel resp. preventing material damage. They are being stressed by the presently described signal terms and in addition marked with warning symbols (pictograms). The applied symbols have the following meanings:

**Danger:** Death, severe injury and/or significant material damage **will be** the consequence, if the appropriate precautions should not be taken.



**Warning:** Death, severe injury and/or significant material damage **may be** the consequence, if the appropriate precautions should not be taken.



**Caution:** Light injury and/or material damage **may be** the consequence, if the appropriate precautions should not be taken.



**Note:** Important information about the product itself, about how to handle the product, to which special attention is being called.



## 2. Safety advices

The valve has been exclusively designed for the use according to the specification in our order confirmation. Any other use is not according to the directives. For resulting damages the user alone is liable. Unauthorized changes, as well as the use of non original **von Rohr** spare parts exclude any responsibility for damages caused. Any change brought to the installation is done at the users own risk.



Maintenance and repair operation may only be done by qualified personnel observing the respective directives.

Actuators bring up great actuating power. Assembly and initiation are to be done under strict observation of the safety instructions.

It is expressly pointed out to follow the instructions for explosive devices where appropriate.

The following instructions are to be observed before any maintenance operations:

- Drain the conduit.
- Be informed about possible dangers, e.g. caused by residues of the operating medium, and take such measures where appropriate. (e.g. safety gloves, safety glasses, etc.)
- Cool down the valve where appropriate.
- Exclude initiation by third party.
- Counteract pressure pads which may be formed in locked conduits.

## 3. Qualified personnel

According to the spirit of this manual, such persons are familiar with assembly, initiation and operation of this product, and have the qualifications for executing their function, like:



- Training or instruction according to the actual standards in safety features maintaining and using appropriate safety equipments.
- Training in first aid.
- Training resp. permission to perform tasks with explosive devices.
- Training at von Rohr Armaturen AG, CH-4132 Muttenz.

## 4. Storage



The following conditions are to be observed:

- Dry and dust-free environment.
- Closed rooms, UV light protected.
- Maximum temperature 30°C.
- Do not remove the spacer ring from the coupling of new valves (relief of the diaphragm).
- When the valve is stored for more than one month, verify the screwed joints – see chapter «Torque table» page 9.

## I. Functional description

Valves of that series are generally used as actuating element according to DIN 19226.

They are used as shut-off or control valves for corrosive, abrasive as well as toxic media in fluid or gaseous state.

The valve is characterized as follows:

- Closing piston, which separates the inner parts from the medium in combination with the diaphragm.
- Wiper, which protects from dirt
- Control connection, which guarantees safety
- Closing pressure limitation, which enhances the life cycle of the diaphragm

## II. Installation

### 1. Mounting location

- The valve should be accessible from at least one side.  
Significant heights require the use of a service platform or similar.
- For nominal bores of more than 100, arrange for a crane resp. a tackle.

### 2. Mounting

The valve is equipped with flanges and is installed into the conduit – see also chapter «Torque table» on page 10.



Attention should be paid to:

- Mounting position:
  - Conduit horizontally
  - Stem vertically
  - Actuator above the valve

Other mounting positions require special arrangements to support the weight!

- No conduit forces must be transmitted to the valve.
- A straight conduit section with a length of at least  $10 \times$  the nominal width needs to be foreseen in front and behind the valve. Installations and branchings are not allowed.

## Usage of flange sealings

- Flange sealings between flanges and the valve should not be used under normal conditions.
- When mounting valves with irregular or deformed flanges, it is recommended to use PTFE coated flat sealings.



### 3. Type plate

Armaturen AG			
von Rohr	type		
		S/N	
PN	$\Delta p$	bar	kvs
			max. t. °C

The type plate contains the following information:

- Type key
- Serial number
- Technical data (PN,  $\Delta p$ , kvs, t °C max.)

Type key and serial number are always to be indicated when submitting inquiries or ordering spare parts.



### III. Initiation

- Avoid thermal shock!
  - Get the valve slowly to operation temperature.
- Verify impermeability of the body junctions and stem sealings. Tighten screwed joints crossover where required. See chapter «Torque table» page 9.
- Remove splint pin from the coupling of the valve (only on new valves).



### IV. Maintenance

- Regularly clean the stem (5).
  - Bring actuator to upper final position and secure.
  - Clean the stem (5) with a soft cloth, in no case use abrasive paper!



The valve is mostly maintenance free.

After a long operating period or with significantly changing operating conditions, the steps according to chapter «Initiation» page 5 need to be performed where required.

Diaphragms older than 5 years are occasionally to be replaced. It is strongly recommended to replace once dismantled diaphragms.

## V. Dismounting / mounting the valve

### 1. Procedure

Pay attention to the notes in chapter «Security advices» page 3.

- Dismount the valve.
- Clean all parts.
- Assemble inversely:
  - Replace sealings and packings using the new parts.
  - See chapter «Torque table» page 9 for torques of the screwed junctions.
  - After assembly manually move the plug in upper and lower position. The plug should not jerk or scrape. Where required, loosen the flanged joints, center them to each other and retighten them.
  - Initiate the valve according to chapter «Initiation» page 5.
  - To order spare parts, please copy the form on page 10 and fax it to the indicated address.

### 2. Actuator



- Move actuator to mid stroke position and secure.
- Decouple the actuator and remove it.
  - Note assembly advices of the actuator manufacturer!

### 3. Cover flange (bonnet)

- Loosen the screwed junctions (9, 10) between body (1) and bonnet (4).
- Remove bonnet (4).
  - The closing piston (3) and the diaphragm (2) are removed with the bonnet (4).

### 4. Closing piston / stem / diaphragm

- Remove all parts from traverse to splint pin (11–16).
- Carefully remove the closing piston (3) with the diaphragm (2) from the bonnet (4).



- Caution! Do not twist the stem (5)!
- The closing piston (3) is to be removed from the stem (5) by removing the grooved pins (8).



- While mounting, make sure that the diaphragm (2) is correctly connected to the closing piston (3).

## 5. Sealing elements / guidings

- Replace wiper (7)

## 6. Replacing the diaphragm

- The diaphragm valves of series 4 are standard equipped with a PTFE diaphragm / EPDM supporting diaphragm, which are part of the complete bonnet. This assembly has to be dismantled previously, the diaphragm is to be rotated by 90° and removed.

The complete diaphragm is originally delivered convex, i.e. in closing position.

See the following figure for relevant components a the simple replacement.

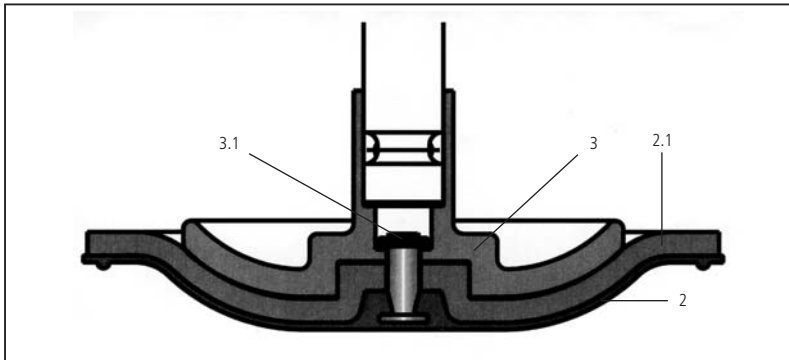

### Mounting the new diaphragm

- Press the diaphragm (2) and the supporting diaphragm (2.1) into the concave open position.
- Put the closing piston (3) onto the diaphragm stud (3.1). Make sure the transversal stud (3.1) lies in the correct position to the closing piston.
- Press the diaphragm and the supporting diaphragm firmly onto the closing piston in order to avoid a slackness between supporting diaphragm and closing piston. Make sure the sealing bead is not damaged.
- Rotate the closing piston 90° against the diaphragm. Then perform the pull control to verify if the bayonet nut is hung-in.
- Press the diaphragm and the supporting diaphragm back into the convex original position. Mount the complete bonnet back onto the body (page 6).
- Set the force limit.
- Turn the nut (14) to the setting screw (15) until the upper stop.
- Close the valve.
- Verify with the permissible pressure  $p_1$ , if the valve is tightly closed.
- Turn the nut (14) as far down that the valve is closed. This will avoid unnecessary pressure on the diaphragm.
- Secure the screw joint of the force limit with Loctite.

VI. Sectional drawing / bill of materials

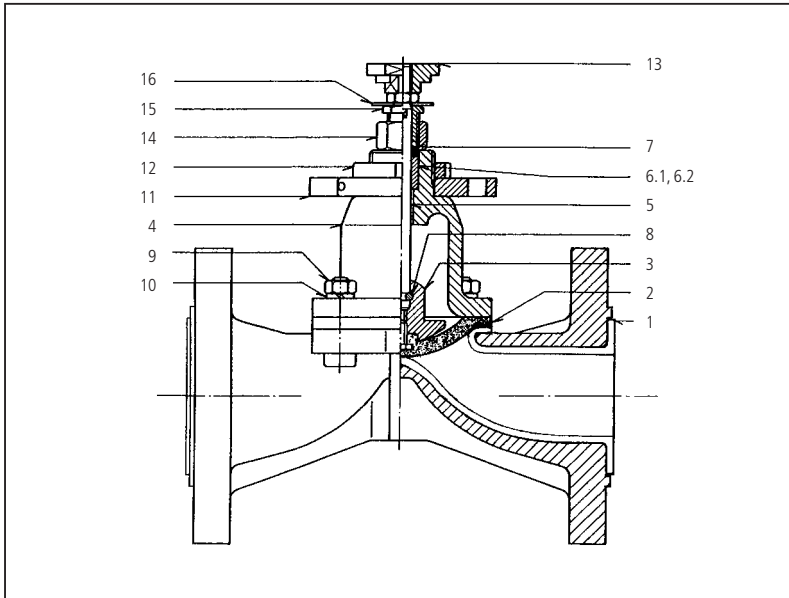

Item		Quantity	Description
1		1	Body
2	*	1	Diaphragm
3		1	Closing piston
4		1	Bonnet
5		1	Stem
6.1		1	Sliding bushing
6.2		1	Insert
7	*	1	Wiper
8		2	Half length taper grooved dowel pin
9		4	Studs and nuts
10		4	Spring washer
11		1	Traverse
12		1	Traverse nut
13		1	Coupling
14		1	Nut
15		1	Setting screw
16		1	Splint pin

Recommended spare parts are flagged with a \*.

## VII. Torque table

### 1. Control cover flange (bonnet fixing)

The torques of the bonnet nuts are to be verified periodically.  
The recommendations are as follows:

- First control: after one month of operation.
- Second control: after six months of operation.
- Further controls: according to previous experiences.

DN	Hexagon nuts		Torques [Nm]
15	4	M6	9
20	4	M6	9
25	4	M8	10
32	4	M8	15
40	4	M10	25
50	4	M10	35
65	4	M12	55
80	4	M16	75
100	8	M12	50
125	8	M16	60
150	10	M16	65
200	14	M16	75

### 2. Flange screw fixing (conduit system)

The mounting of diaphragm valves should be done with a torque spanner.  
The below values are based on standard diaphragm valves and are equipped with a body coating of PFA.

DN	Torque [Nm]
15	15
20	20
25	20
32	25
40	30
50	40
65	50
80	45
100	50
125	55
150	75
200	95

## VIII. Spare parts offer / orders

To: von Rohr Armaturen AG  
 Fichtenhagstrasse 4  
 CH-4132 Muttenz  
 Phone +41 (0) 61 467 91 20  
 Fax +41 (0) 61 467 91 21  
 e-mail: info@von-rohr.ch

Sender

In reference to the serial number(s):

---



---

- We would like to request a spare parts bid for the following items
- We would like to order the following spare parts

### Bill of materials

Item	Description	Quant
1	Body	
2 *	Diaphragm	
3	Closing piston	
4	Bonnet	
5	Stem	
6.1	Sliding bushing	
6.2	Insert	
7 *	Wiper	
8	Half length taper grooved dowel pin	
9	Studs and nuts	
10	Spring washer	
11	Traverse	
12	Traverse nut	
13	Coupling	
14	Nut	
15	Setting screw	
16	Splint pin	

Recommended spare parts are flagged with a \*.  
 For quantity of parts see «bill of material» page 8.